

## AIRPAX® | 6600 Series

### 8-PIN DIP BIMETAL DISC THERMOSTAT

#### FEATURES

- RoHS compliant per EU directive 2002 / 95 / EC
- 8-pin DIP international electronic package standard
- Ideal for surface and air sensing on PC boards
- Gold-plated contacts
- 30,000 life cycles @ max standard amperage
- 100,000 life cycles @ max gold contact amperage

#### DESCRIPTION

The Airpax™ 6600 series is a RoHS compliant, positive snap action, single pole / single throw, sub-miniature bimetallic thermostat which provides accurate and reliable sensing and switching in a single device.

The 6600 series thermostat dimensionally conforms to the international product package standard 8-pin DIP (N8A Dual Inline Package). The 6600 is ideally suited for use on printed circuit boards. Its size and shape conserves space on crowded PC boards and can be installed using auto-insertion equipment. The device is sealed to withstand wave soldering and board washing operations.

The 6600 provides fast, positive response with excellent repeatability. The thermostat has a switch capability of up to 1 amp for 48 VDC or 120 VAC for 30,000 cycles, and achieves low-level switching down to 0.001 A to 0.020 A at 5 VDC for 100,000 cycles. Temperature is pre-set at the factory and is non-adjustable in the field.

Applications include computers and computer peripherals, aircraft, automotive and test equipment. Typical uses include turning on an indicator light, sounding an audible alarm, switch on a control circuit to send a message to a display screen or even switching a circuit to shut down a system.

The 6600 thermostat is temperature tested in a computer controlled automated test equipment air-oven. Due to the ideal conditions under which it is tested, independent customer testing may be necessary to ensure that the correct calibration is utilized in the application.

It is the customer's responsibility to determine whether the product is proper for customer's use and application.

#### OPERATION SCHEMATICS

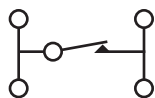

Schematic for  
Open on Rise  
Operation

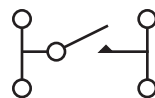

Schematic for  
Close on Rise  
Operation

## SPECIFICATIONS

Contact Resistance	50 milliohms max (before and after rated life)					
Contact Ratings	<i>Approved per VDE 0631/12.83</i>			<i>Approved per cЯUus E36687</i>		
	Cycles	Voltage	Amps (resistive)	Cycles	Voltage	Amps (resistive)
	30,000	48 VDC Test, Class 1	1.0	30,000	48 VDC	1.0
	30,000	120 VAC Test, Class 1	1.0	30,000	120 VAC	1.0
	100,000	5 VDC Test, Class II	0.020 (gold)	100,000	5 VDC	0.020 (gold)
			100,000	5 VDC	0.001 (gold)	
Contact Operations	Either close on rise (make) or open on rise (break)					
Operating Temperature	40°C to 130°C (104°F to 266°F)					
Temperature Tolerance	Standard of ±5°C (±9°F) with nominal operating temperature settings in 5°C increments					
Short Term / Long Term Exposure Limit	Short = 260°C (500°F), 10 second duration			Long = -55°C to 160°C (-67°F to 320°F)		
Dielectric Strength	1480 VAC 60Hz, 1 second duration terminals to case					
Insulation Resistance	100 Mohms at 500 VDC					
Contact Bounce	3 milliseconds max (make)					
Vibration	Per Mil-Std-202, method 204D, test condition D, 10 to 2,000 Hz					
Shock	Per Mil-Std-202, method 213, test condition C, 100 G's for 6 millisecond duration, ½ sine wave					
Seal	High temperature epoxy sealed for wave soldering and cleaning, moisture proof per Sensata specification S-722 (unit will not leak while submerged in 9" of water for a minimum of two minutes)					
Base Material	PPS (Polyphenylene Sulfide), 94 VO rated					
Terminal Material	65% Copper, 18% Nickel					
Contact Material	Gold-plated or overlay, silver crossbar					
Chemical Resistance	Unit is resistance to water, salt, alcohol, ammonia, trichlorethane and most other organic solvents					
Soldering Heat Resistance	Per Mil-Std-202F, method 210A, test condition E					
US Patent Number	4,620,175					
Weight	Approximately 0.45 grams					
Mechanical Life	1,000,000 operations					
Agency Approvals	cЯUus recognized E36687 VDE approval 0631/12.83 RoHS Compliant per EU Directive 2002/95/EC					

## DIMENSIONAL SPECIFICATIONS, inches [mm]

### Standard 8-Pin DIP Configuration

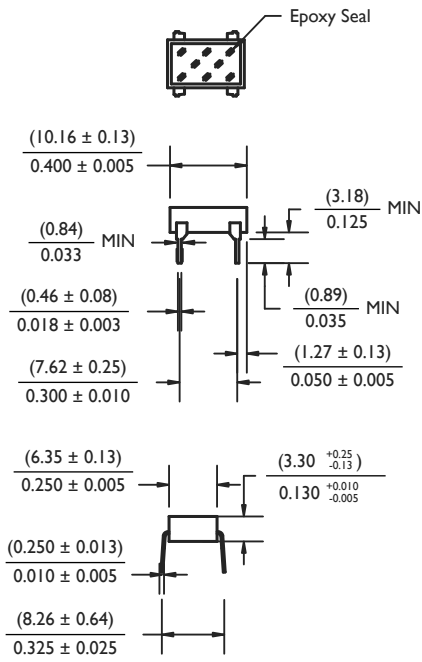

### Surface Mount (Gullwing, SMT) Configuration

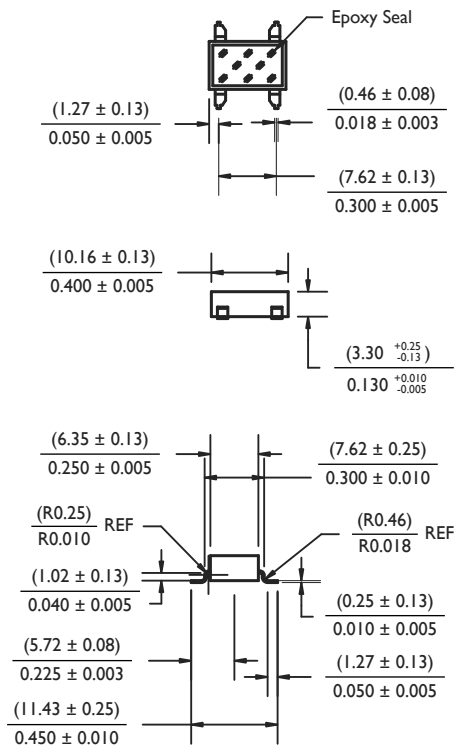

## STANDARD PACKAGING

Standard and surface mount samples and production orders will be shipped in plastic, industry standard DIP shipping tubes.

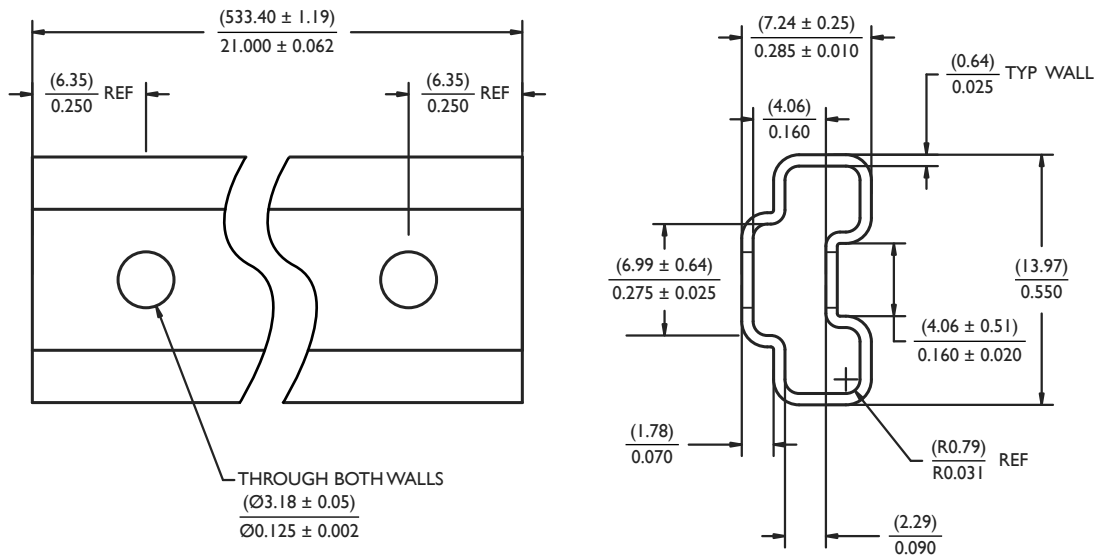

## STANDARD TEMPERATURE CALIBRATION TABLE

Each thermostat part number consists of functional “building blocks” to enable the user to specify clearly and precisely the desired characteristics in each category. Select the proper code in each category, then transfer it to the box indicated. Unless a special requirement is indicated, the part number will be complete when the proper temperature is selected. If you have a special requirement, please call Sensata for a factory assigned number to complete the part number.

### Example :

A 66F095 thermostat will close (make contact) on a rising temperature from 90°C to 100°C and will reset open (break contact) on a falling temperature within a window of no greater than 6°C lower than the actual close temperature and no less than 60°C ambient temperature.

Special requirements require a 4 digit manufacturing dash number for ordering special features, 4 digit marking may not appear as part of the marking on the thermostat.

Special requirements may include VDE,  $\pm 3.0^{\circ}\text{C}$  ( $\pm 5.4^{\circ}\text{F}$ ) operating temperature tolerance, or surface mount (gullwing, SMT).

Temperature set point calibration is checked at Sensata Technologies with precision test equipment traceable to the US National Institute of Standards and Technology and Proven Methods. Because customer checking methods may differ, a typical variance allowed for correlation is  $\pm 1.1^{\circ}\text{C}$  ( $\pm 2.0^{\circ}\text{F}$ ).

OPERATE ( $\pm 5^{\circ}\text{C}$ )	MIN DIFFERENTIAL ( $^{\circ}\text{C}$ )	MIN RESET ( $^{\circ}\text{C}$ )
40	4	20
45	4	20
50	4	30
55	4	30
60	4	40
65	4	40
70	4	50
75	4	50
80	6	55
85	6	55
90	6	60
95	6	60
100	6	70
105	6	70
110	6	80
115	6	85
120	9	90
125	9	90
130	9	90

## DECISION TABLES

